

Manhattan Basin Mixer

A clean, modern interpretation of a classical design, the Manhattan collection presents a unique blend of simplistic lines and smooth curves. Architectural forms of graceful contours give a dynamic style with enhanced practicality. A harmonious synthesis between form, function and aesthetics.

Features: Easiglide® 1/4 turn ceramic spindles. Patented Broclean® filtration system. Swivel spout.

Finish: Available in all Brodware finishes.

Installation: Maximum bench top thickness = 25mm.

WELS: 6 STAR Rated. 4.5 L/min. Registration number TM29093

Specifications



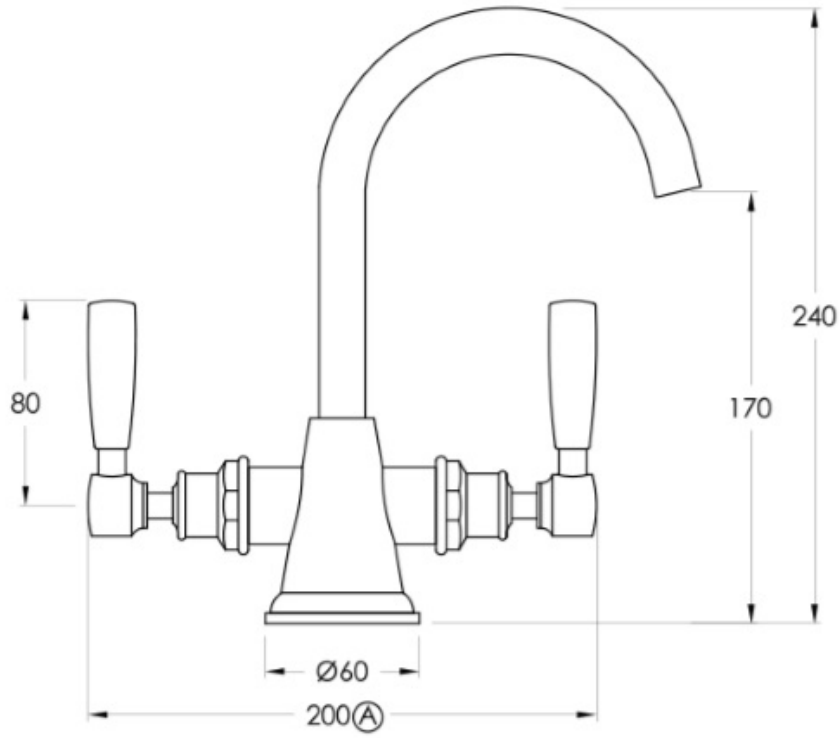

Brodware

